



Cabazon Water District
14618 Broadway Street • P.O. Box 297
Cabazon, California 92230

FINANCE & AUDIT COMMITTEE MEETING

AGENDA

Meeting Location:
Cabazon Water District Office
14618 Broadway Street
Cabazon, California 92230

Meeting Date:
Tuesday, January 15, 2019 – 5:00 PM

CALL TO ORDER,
PLEDGE OF ALLEGIANCE,
ROLL CALL
FINANCE & AUDIT COMMITTEE

1. Discussion: Finance & Audit Committee Report
 - Balance Sheet
 - Profit and Loss Budget Comparison
2. Finance & Audit Committee District Payables Review and Approval/Signing

PUBLIC COMMENT

Any person may address the Board of Directors at this time on any matter within the subject matter jurisdiction of the Cabazon Water District; however, any matter that requires action will be referred to staff for investigation and reported at a subsequent Board of Directors meeting. The Board of Directors is prohibited by law from discussing or taking immediate action on items during this public comment period. To comment on specific agenda items, please advise the Board secretary prior to the meeting. **Each public comment will be limited to three (3) minutes. Individuals may not give their time away to another spokesperson. After two (2) minutes, the speaker will be notified that he/she has one (1) minute remaining. AB 1234 ORAL REPORTS (Gov. Code Sec. 53232.3(d))**

ADJOURNMENT

ADA Compliance Issues

In compliance with the Americans with Disabilities Act & Government Code Section 54954.2, if special assistance is needed to participate in a Board meeting, please contact the Clerk of the Board at (951) 849-4442. Notification of at least 48 hours prior to meeting time will assist staff in assuring that reasonable arrangements can be made to provide accessibility at the meeting.



Cabazon Water District
14618 Broadway Street • P.O. Box 297
Cabazon, California 92230

REGULAR BOARD MEETING

AGENDA

Meeting Location:
Cabazon Water District Office
14618 Broadway Street
Cabazon, California 92230

Meeting Date:
January 15, 2019 – 6:00 PM

CALL TO ORDER

PLEDGE OF ALLEGIANCE

REMEMBRANCE OF OUR SERVICE MEN AND WOMEN

ROLL CALL

CONSENT CALENDAR

All matters in this category are considered to be consistent with the Board/District goals, District Policies and Regulations adopted and/or approved by the Board of Directors, and will be enacted in one motion. There will be no separate discussion of these items. If discussion is required, items may be removed from the consent calendar and will be considered separately.

1. **Approval of:**
 - a. Finance and Audit Committee Meeting Minutes and Warrants approved by the committee
December 17, 2019
 - b. Regular Board Meeting Minutes and Warrants of December 17, 2019
2. **Warrants – None**
3. **Awards of Contracts – None**

UPDATES

1. **Update:** San Gorgonio Pass Regional Water Alliance Update
(by Director Israel)
2. **Update:** Manager's Operations Report
(by General Manager Louie)

NEW BUSINESS

1. Discussion/Action: Customer Concern: Paul Oshideri – Unpaid Tenant Bills
2. Discussion/Action: Adoption of current County of Riverside requirements on new single family dwelling construction to install a private fire protection system (fire sprinklers) - ¾" water meter versus 1" water meter

OLD BUSINESS

1. Discussion: Sustainable Groundwater Management Act (SGMA) Update (by General Manager Louie)
2. Discussion: Update on Interconnection between Morongo Tribal reservoir and Tank #2 and Providing or allowing electric power (Edison) to their production well and reservoir control panel
3. Discussion/Action: CalMutuals - Adan Ortega, Executive Director is forming the Community Water System Alliance (CWSA) – Prevent "Smaller & Poorer" to be unnecessarily taxed by the State and form a "mutual aid well-functioning water systems and those that may be at the brink of failing."

PUBLIC COMMENTS

Any person may address the Board of Directors at this time on any matter within the subject matter jurisdiction of the Cabazon Water District that is not listed on the agenda; however, any matter that requires action will be referred to staff for investigation and reported at a subsequent Board of Directors meeting. The Board of Directors is prohibited by law from discussing or taking immediate action on items during this public comment period. To comment on specific agenda items, please advise the Board secretary prior to the meeting. Each public comment will be limited to three (3) minutes. Individuals may not give their time away to another spokesperson. After two (2) minutes, the speaker will be notified that he/she has one (1) minute remaining. AB 1234 ORAL REPORTS (Gov. Code Sec. 53232.3(d))

GENERAL MANAGER/BOARD COMMENTS

1. Future Agenda Items

The Board Chair or the majority of the Board may direct staff to investigate and report back to an individual(s) and the Board on matters suggested or direct the General Manager/Board Secretary to place the matter on a future Board meeting.

- Suggested agenda items from the Public.
- Suggested agenda items from Management.
- Suggested agenda items from Board Members.

2. Management Comments

Staff members may speak on items of information not requiring comment or discussion to the Board and public. Topics which may be included on a future meeting agenda may be presented but cannot be discussed. (3 minutes)

3. Board Member Comments

Board members may speak on items of information not requiring comment or discussion to the Board and public. (3 minutes)

MISCELLANEOUS

1. Future Board Items/Next Board Meeting Date(s)

- a. Finance & Audit Workshop – Tuesday – February 19, 2019, 5:00 pm
- b. Regular Board Meeting – Tuesday – February 19, 2019, 6:00 pm
- c. Personnel Committee – None
- d. San Geronio Pass Regional Water Alliance – Alliance Meeting – Wednesday – January 23, 2019

ADJOURNMENT

ADA Compliance Issues

In compliance with the Americans with Disabilities Act & Government Code Section 54954.2, if special assistance is needed to participate in a Board meeting, please contact the Clerk of the Board at (951) 849-4442. Notification of at least 48 hours prior to meeting time will assist staff in assuring that reasonable arrangements can be made to provide access.



Cabazon Water District
14618 Broadway Street • P.O. Box 297
Cabazon, California 92230

FINANCE & AUDIT COMMITTEE MEETING

Minutes

Meeting Location:
Cabazon Water District Office
14618 Broadway Street
Cabazon, California 92230

Meeting Date:
Monday, December 17, 2018 – 5:00 PM

CALL TO ORDER,
PLEDGE OF ALLEGIANCE,
ROLL CALL

Director Wargo - Yes
Director Israel - Yes
Calvin Louie (General Manager) - No
Juliana Salcido, Board Secretary - Yes
Cindy Byerrum, Financial Consultant - No

***Note: This meeting was recorded by the District - Yes**

FINANCE & AUDIT COMMITTEE

1. Discussion: Finance & Audit Committee Report
 - Balance Sheet
 - Profit and Loss Budget Comparison

Balance Sheet:

- The District's combined Cash with Chase and LAIF balance was \$815,037 at month end.
The District's total liabilities were approximately \$1.128 million at month end.

Profit and Loss:

- Line 16 Property Taxes: YTD is trending near 2% due to the timing of property tax receipts which are mainly received after December 10th and April 10th when property tax payments are due to the County of Riverside Tax Collector's Office.
- Line 19 Interest Income YTD is trending at 51% due to higher interest revenues than anticipated.
- Line 44 Generator Service Contract: YTD is over budget due to higher than expected maintenance costs for the Apache Generator.
- Line 80 Legal Services: YTD is at 59% due to higher than anticipated legal services related to water & personnel related issues in the first half of the fiscal year.
- Line 87 Other Fees/SWRCB: YTD is at 60% due to timing of Riverside County Assessment Fees. A \$2K annual fee was paid in August.
- Line 93 Tractor Expenses: YTD is over budget due to a \$1.8K invoice from PowerPlan for Tractor grease fitting maintenance.

As of November 30th, the fiscal year-to-date net income is \$34,562.

2. Finance & Audit Committee District Payables Review and Approval/Signing

PUBLIC COMMENT

***No Public Comment**

Any person may address the Board of Directors at this time on any matter within the subject matter jurisdiction of the Cabazon Water District; however, any matter that requires action will be referred to staff for investigation and reported at a subsequent Board of Directors meeting. The Board of Directors is prohibited by law from discussing or taking immediate action on items during this public comment period. To comment on specific agenda items, please advise the Board secretary prior to the meeting. **Each public comment will be limited to three (3) minutes.** Individuals may not give their time away to another spokesperson. **After two (2) minutes, the speaker will be notified that he/she has one (1) minute remaining.** AB 1234 ORAL REPORTS (Gov. Code Sec. 53232.3(d))

ADJOURNMENT

Motion to adjourn at 17:10 hr. made by Director Israel and 2nd by Director Wargo.

Director Wargo - Aye

Director Israel - Aye

Meeting adjourned at 17:10 hr. on Tuesday, December 17, 2018

Robert Lynk, Board Chair
Board of Directors
Cabazon Water District

Juliana Salcido, Secretary
Board of Directors
Cabazon Water District

ADA Compliance Issues

In compliance with the Americans with Disabilities Act & Government Code Section 54954.2, if special assistance is needed to participate in a Board meeting, please contact the Clerk of the Board at (951) 849-4442. Notification of at least 48 hours prior to meeting time will assist staff in assuring that reasonable arrangements can be made to provide accessibility at the meeting.



Cabazon Water District
14618 Broadway Street • P.O. Box 297
Cabazon, California 92230

**REGULAR BOARD MEETING
MINUTES**

Meeting Location:
Cabazon Water District Office
14618 Broadway Street
Cabazon, California 92230

Meeting Date:
December 17, 2018 – 6:00 PM

CALL TO ORDER
PLEDGE OF ALLEGIANCE
REMEMBRANCE OF OUR SERVICE MEN AND WOMEN
ROLL CALL
CONSENT CALENDAR

Director Martin Sanderson - Present
Director Maxine Israel - Present
Director Sarah Wargo - Present
Director Alan Davis - Present
Director Robert Lynk - Present

Calvin Louie, General Manager - Present
Juliana Salcido, Board Secretary - Present
Cindy Byerrum, Financial Consultant - Absent
Steve Anderson, Best Best & Krieger Law Firm - Absent
Joseph Ortiz, Best Best & Krieger Law Firm - Absent

Note: This meeting was recorded by the District - Yes

All matters in this category are considered to be consistent with the Board/District goals, District Policies and Regulations adopted and/or approved by the Board of Directors, and will be enacted in one motion. There will be no separate discussion of these items. If discussion is required, items may be removed from the consent calendar and will be considered separately.

1. Approval of:

- a. Finance and Audit Committee Meeting Minutes and Warrants approved by the committee November 20, 2018
- b. Regular Board Meeting Minutes and Warrants of November 20, 2018

Motion to approve consent calendar item(s) (a.) Finance and Audit Committee Meeting Minutes and Warrants approved by the committee November 20, 2018 (b.) Regular Board Meeting Minutes and Warrants of November 20, 2018 made by Director Israel and 2nd by Director Wargo.

Director Sanderson - Aye
Director Israel - Aye
Director Wargo - Aye
Director Davis - Aye
Director Lynk - Aye

2. Warrants – None
3. Awards of Contracts – None

UPDATES

1. Update: San Gorgonio Pass Regional Water Alliance Update
(by Director Israel)

*Note: No update

2. Update: Manager's Operations Report
(by General Manager Louie)

- Update on Well 5# Rehabilitation: Pictures were displayed from a second water well video report that was filmed on 12/13/18. Calvin notified the board that he is currently waiting on recommendations from Krieger & Stewart engineers.
- Attempt theft of Fire Hydrant: On 12/12/18 at 0645 hr. a leaking fire hydrant was spotted by Wolny on the south shoulder of Esperanza Ave. Upon further investigation it was proposed that an unknown persons were attempting to steal the fire hydrant.
- LSCI: Calvin informed the board that CalOSHA training has been executed and preparations will began at the start of 2019
- Tank 4#: An unknown substance was discharging from the base of the water tank. Pictures were displayed. Louie informed the board that someone was coming to investigate the substance the following day.

NEW BUSINESS

1. Discussion: CalMutuals - Adan Ortega, Executive Director is forming the Community

Water System Alliance (CWSA) – Prevent “Smaller & Poorer” to be unnecessarily taxed by the State and form a “mutual aid well-functioning water systems and those that may be at the brink of failing.”

- Adan Ortega and Dave Armstrong provided a presentation on Community Water System Alliance (CWSA) and approval to contribute funding.
- The board discussed the pros and cons of the alliance.
- After review the board agreed to table any further discussion until next month's meeting.

*A quick recess was taken at 18:43 hr. and the meeting resumed at 18:53 hr.

OLD BUSINESS

1. Discussion: **Sustainable Groundwater Management Act (SGMA) Update (by General Manager Louie)**
 - DWR sent over the final version of the Prop 1 Grant.
 - Jeff Davis advised the SGPGSAS.org is under development
2. Discussion/Action: **Customer Concern: Diaz, Maumee Lane, Acct No. 488692D – Staff Report of Field investigation of high usage versus water meter accuracy**
 - Louie informed the board that customer invited him and the field crew to their home, and the residents verbally told them all the water was shut off. No leak was detected. Calvin offered them to have the meter tested but they declined due to not wanting to pay for the test.

Motion to deny any forgiveness toward the water bill made by Director Israel and 2nd by Director Sanderson.

**Director Sanderson - Aye
Director Israel - Aye
Director Wargo - Aye
Director Davis - Aye
Director Lynk - Aye**

PUBLIC COMMENTS *Note: No Public Comment

Any person may address the Board of Directors at this time on any matter within the subject matter jurisdiction of the Cabazon Water District that is not listed on the agenda; however, any matter that requires action will be referred to staff for investigation and reported at a subsequent Board of Directors meeting. The Board of Directors is prohibited by law from discussing or taking immediate action on items during this public comment period. To comment on specific agenda items, please advise the Board secretary prior to the meeting. Each public comment will be limited to three (3) minutes. Individuals may not give their time away to another spokesperson. After two (2) minutes, the speaker will be notified that he/she has one (1) minute remaining. AB 1234 ORAL REPORTS (Gov. Code Sec. 53232.3(d))

GENERAL MANAGER/BOARD COMMENTS

1. Future Agenda Items

The Board Chair or the majority of the Board may direct staff to investigate and report back to an individual(s) and the Board on matters suggested or direct the General Manager/Board Secretary to place the matter on a future Board meeting.

- Suggested agenda items from the Public.
- Suggested agenda items from Management.
- Suggested agenda items from Board Members.

2. Management Comments

Staff members may speak on items of information not requiring comment or discussion to the Board and public. Topics which may be included on a future meeting agenda may be presented but cannot be discussed. (3 minutes)

3. Board Member Comments

Board members may speak on items of information not requiring comment or discussion to the Board and public. (3 minutes)

- Director Sanderson presented a statement addressing Mr. Covington's request for Cabazon Water District to share funding with Morongo Reservation

MISCELLANEOUS

1. Future Board Items/Next Board Meeting Date(s)

- a. Finance & Audit Workshop – Tuesday – January 15, 2019, 5:00 pm
- b. Regular Board Meeting – Tuesday – January 15, 2019, 6:00 pm
- c. Personnel Committee – None
- d. San Geronio Pass Regional Water Alliance – Alliance Meeting – Wednesday – January 23, 2019

ADJOURNMENT

*Note: No motion or roll call vote was made, but there was no objections voiced by either the Board or Public.

Meeting adjourned at 19:28 hr. on December 17, 2018.

Robert Lynk, Board Chair
Board of Directors
Cabazon Water District

Juliana Salcido, Secretary
Board of Directors
Cabazon Water District

ADA Compliance Issues

In compliance with the Americans with Disabilities Act & Government Code Section 54954.2, if special assistance is needed to participate in a Board meeting, please contact the Clerk of the Board at (951) 849-4442. Notification of at least 48 hours prior to meeting time will assist staff in assuring that reasonable arrangements can be made to provide access.

Cabazon Water District

Balance Sheet

December 31, 2018

Dec 31, 18

1 ASSETS

2 Current Assets

3 Checking/Savings

4 General Bank Account-Chase 170,147

5 Payroll Bank Account-Chase 106,707

6 Trust Account-Chase (Cust. Deposits) 17,834

7 Local Petty Cash 100

8 Total Checking/Savings 294,788

9 Accounts Receivable 207,254

10 LAIF 561,847

11 Bank of NY Trustee Accounts 57,332

12 Prepaid Expenses 9,752

13 Inventory Total 93,672

14 Total Other Current Assets 929,857

15 Total Current Assets 1,228,379

16 Fixed Assets

17 Construction in Process

18 CIP Cabazon Outlets Expansion 9,692

19 CIP Super Map 19,015

20 CIP 50100 Main St. Property 85,460

21 Total Construction in Process 114,167

22 Tools and Equipment 123,319

23 Source of Supply 1,552,226

24 Transmission & Distribution 10,216,143

25 Buildings & Structures 12,281

26 Water Treatment 8,800

27 Office Furniture and Equipment 71,808

28 Intangible Plant 11,032

29 Vehicles 106,309

30 Land 689,548

31 Accumulated Depreciation (5,352,138)

32 Total Fixed Assets 7,553,494

33 **TOTAL ASSETS** 8,781,872

34 LIABILITIES & EQUITY

35 Liabilities

36 Current Liabilities

37 Accounts Payable 59,401

38 Other Current Liabilities

39 Customer Deposits - Co 1 4,850

40 Customer Deposits - Co 2 5,854

41 Total Customer Deposits 10,704

42 Accrued Vacation Pay 10,051

43 DWR-HS Payable - Current 38,425

44 Current Portion Zion's Bank Ln 78,870

45 Accrued Payroll 7,565

Cabazon Water District

Balance Sheet

December 31, 2018

		Dec 31, 18
46	Accrued Payroll Taxes	553
47	Accrued Interest	5,225
48	Accrued Expenses	6,419
49	Employee Deductions	134
50	Total Other Current Liabilities	<u>157,945</u>
51	Total Current Liabilities	217,346
52	Long Term Liabilities	
53	DWR-H Loan Payable (Payoff '26)	318,500
54	Zion's Bank Long Term (2023)	335,745
55	RCEDA Loan Payable	300,000
56	Total Long Term Liabilities	<u>954,245</u>
57	Total Liabilities	<u>1,171,592</u>
58	Total Equity	<u>7,610,281</u>
59	TOTAL LIABILITIES & EQUITY	<u>8,781,872</u>

Cabazon Water District

Profit & Loss

December 2018

	Dec-18	Current YTD	Budget	YTD (50%)
1 REVENUES				
2 OPERATING INCOME				
3 Base Rate - Water Bills	68,344	411,928	811,800	51%
4 Commodity Sales	19,606	186,020	327,500	57%
5 DHPO Contract	13,048	115,703	225,900	51%
6 Fire Sales - Water Bills	226	1,354	2,500	54%
7 Fire Flow Income	-	-	400	0%
8 Penalty Fees - Water Bills	3,222	23,556	48,300	49%
9 New Account Fees - Water Bills	145	870	1,800	48%
10 Incident Fee - Water Bills	-	-	400	0%
11 Returned Check Fees	30	300	600	50%
12 Basic Facilities Fee	3,974	3,974	64,900	6%
13 Stand By Fees - Tax Revenue	3,704	19,190	113,600	17%
14 TOTAL OPERATING INCOME	112,299	762,895	1,597,700	48%
15 NON-OPERATING INCOME				
16 Property Taxes	52	1,197	60,900	2%
17 Cell Tower Lease Income	2,046	12,278	22,100	56%
18 Misc. Non-Operating Income	26	26	-	0%
19 Interest Income	424	6,085	11,200	54%
20 TOTAL NON-OPERATING INCOME	2,549	19,586	94,200	21%
21 TOTAL REVENUES	114,848	782,481	1,691,900	46%
22 EXPENSES				
23 PAYROLL				
24 Directors Fees	1,100	8,200	20,000	41%
25 Management & Customer Service				
26 Customer Accounts	4,574	27,236	51,700	53%
27 Business Admin Manager	3,383	35,254	66,800	53%
28 Office Assistant	3,304	12,996	-	0%
29 General Manager	6,662	43,257	84,100	51%
30 Total Management & Customer Service	17,924	118,742	202,600	59%
31 Field Workers	13,755	76,545	146,300	52%
32 Employee Benefits Expense				
33 Workers Comp.	113	4,290	8,800	49%
34 Employee Health Care	8,311	47,237	86,800	54%
35 Pension	3,532	26,720	67,800	39%
36 Total Employee Benefits Expense	11,956	78,247	163,400	48%
37 Payroll Taxes	2,528	17,283	29,300	59%
38 TOTAL PAYROLL	47,262	299,017	561,600	53%
39 OPERATIONAL EXPENSES				
40 Facilities, Wells, T&D				
41 Lab Fees	270	4,422	8,500	52%
42 Site Landscaping & Maintenance	90	270	700	39%
43 Meters	-	300	4,600	7%

Cabazon Water District

Profit & Loss

December 2018

	Dec-18	Current YTD	Budget	YTD (50%)	
44	Generator Service Contractor	-	1,525	1,300	117%
45	Utilities - Wells	9,508	58,015	126,100	46%
46	SCADA	28	165	300	55%
47	Line R&M Contractor	-	-	12,500	0%
48	Line R&M Materials	263	14,241	60,000	24%
49	Well Maintenance	34,948	40,406	36,200	112%
50	Security	1,128	9,690	18,400	53%
51	Engineering Services	2,735	22,277	48,600	46%
52	Chlorinators	-	-	100	0%
53	Facilities, Wells, T&D - Other	-	5,012	10,000	50%
54	Total Facilities, Wells, T&D	48,970	156,322	327,300	48%
55	Utilities - Office				
56	Electricity	1,096	9,656	15,900	61%
57	Gas	69	239	710	34%
58	Telephone	811	4,759	9,500	50%
59	Trash Pickup & Office Cleaning	364	2,212	4,400	50%
60	Total Utilities - Office	2,339	16,866	30,510	55%
61	Office Expenses				
62	Water Billing System	177	1,064	2,100	51%
63	Supplies & Equipment	798	8,643	9,700	89%
64	Copier and Supplies	768	5,830	6,000	97%
65	Dues & Subscriptions	90	90	1,700	5%
66	Postage	606	3,352	7,700	44%
67	Printing & Publications	-	509	6,100	8%
68	Leases & Rents	-	165	300	55%
69	Computer Services	2,697	13,451	36,800	37%
70	Office Radio	-	-	500	0%
71	Office Storage	500	3,000	6,200	48%
72	Air Conditioning Servicing	398	2,388	4,600	52%
73	Fire Alarm System Servicing	52	312	700	45%
74	Office Expenses - Other	-	546	1,300	42%
75	Total Office Expenses	6,086	39,350	83,700	47%
76	Support Services				
77	Temporary Labor	-	-	10,000	0%
78	Financial Audit	-	7,855	22,100	36%
79	Accounting	2,418	21,128	36,000	59%
80	Legal Services	3,300	35,059	53,600	65%
81	Bank Service Charges	54	425	700	61%
82	Payroll Service	311	2,092	4,100	51%
83	Website Support	-	375	1,700	22%
84	General Liability Insurance	1,946	11,203	21,000	53%
85	Total Support Services	8,029	78,136	149,200	52%
86	Training/Travel	2,968	5,143	41,000	13%

Cabazon Water District

Profit & Loss

December 2018

	Dec-18	Current YTD	Budget	YTD (50%)
87 Other Fees/SWRCB	2,285	5,990	6,200	97%
88 Service Tools & Equipment				
89 Shop Supplies and Small Tools	1,110	3,649	21,100	17%
90 Vehicle Fuel	536	6,504	12,800	51%
91 Employee Uniforms	517	1,294	1,500	86%
92 Safety	9,864	9,864	500	1973%
93 Tractor Expenses	-	1,856	1,000	186%
94 Equipment Rental	-	-	2,100	0%
95 Service Trucks - R&M	494	3,628	13,900	26%
96 Water Ops Phone & Internet	88	528	900	59%
97 Total Service Tools & Equipment	12,608	28,396	53,800	53%
98 NON-OPERATING EXPENSES				
99 Grant & Loan Processing Fee	-	1,325	1,600	83%
100 DWR Interest Expense	-	4,978	10,300	48%
101 DHPO Interest Expense	-	5,162	9,800	53%
102 Bad Debt Expense	-	-	1,200	0%
103 Miscellaneous	-	-	1,600	0%
104 Prior Year Income / Expense	-	-	-	0%
105 Depreciation Expense	-	-	266,300	0%
106 TOTAL NON-OPERATING EXPENSES	-	11,465	290,800	4%
107 TOTAL EXPENSES	130,547	640,686	1,544,110	41%
108 TOTAL INCOME BEFORE CAPITAL & GSA	(15,699)	141,795	147,790	96%
109 DHPO Capacity Credit	(1,750)	(10,500)	(21,000)	50%
CAPITAL PROJECTS				
110 Main Street Improvements (Icehouse Imp.)	-	(29,280)	(60,000)	49%
111 Meter Replacements & Other Capital	-	(9,048)	(22,000)	41%
112 New Vehicle Purchase	-	-	-	0%
113 Vehicle Upgrades	-	(8,419)	-	0%
114 TOTAL CAPITAL PROJECTS	-	(46,748)	(82,000)	57%
115 DEBT - PRINCIPAL				
116 Debt Service Principal - DWR	-	(19,367)	(38,400)	50%
117 Debt Service Principal - DHPO (Zion)	-	(39,435)	(78,900)	50%
118 TOTAL DEBT - PRINCIPAL	-	(58,802)	(117,300)	50%
119 SGMA / GSA	-	(8,632)	(60,000)	14%
120 NET INCOME / (LOSS)	(17,449)	17,113	(132,510)	

No assurance is provided on these financial statements.

The financial statements do not include a statement of cash flows.

Substantially all disclosures required by accounting principles generally accepted in the United States are not included.

DRAFT

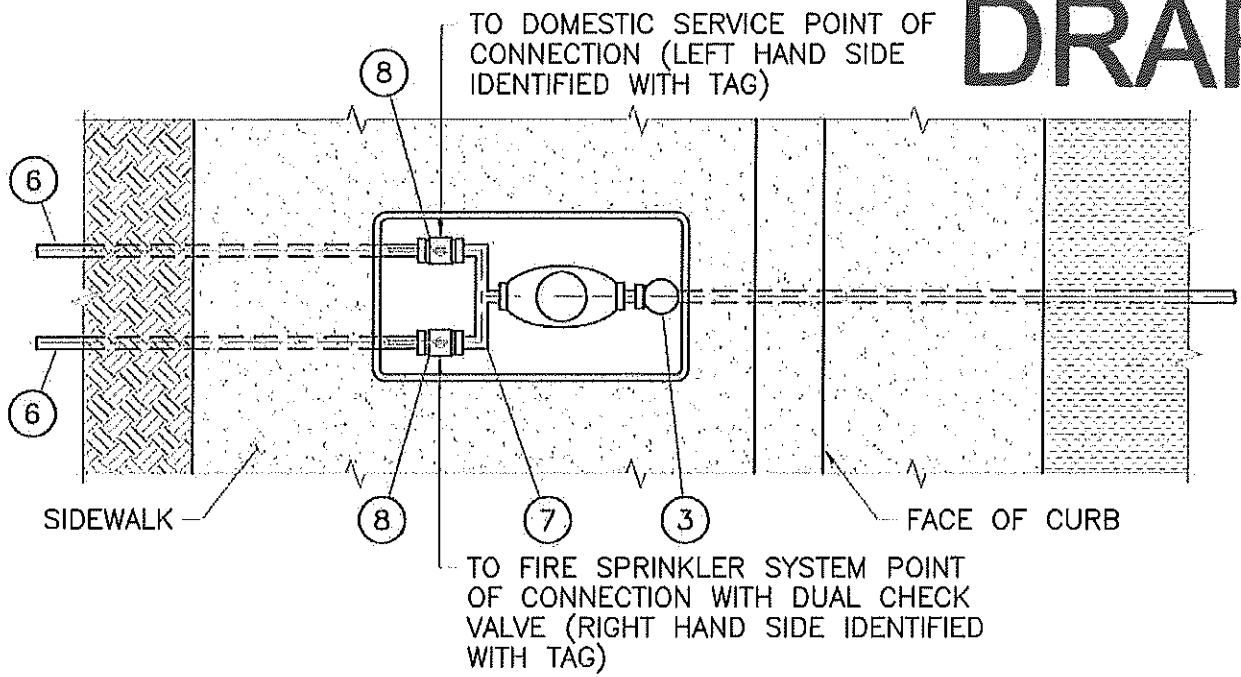

PLAN

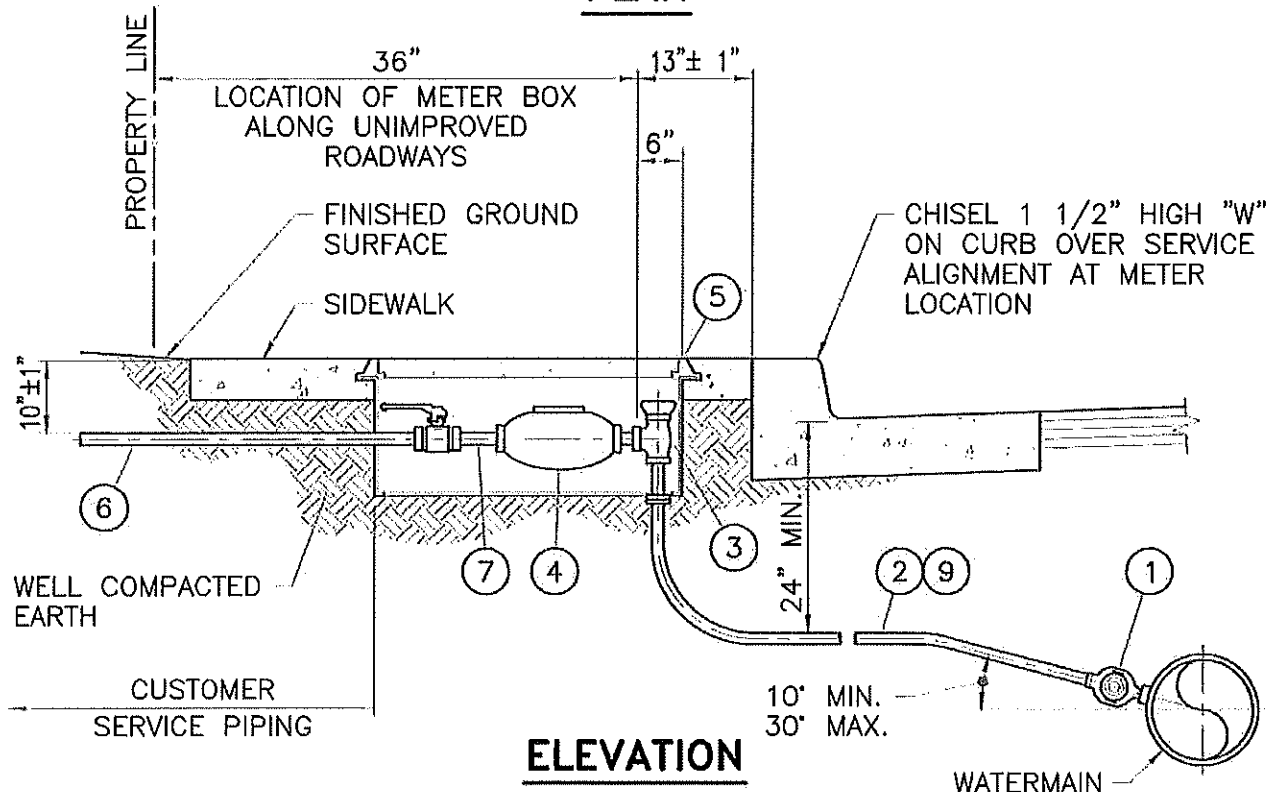

ELEVATION

APPROVED BY DISTRICT WATER ENGINEER RCE No. DATE	CABAZON WATER DISTRICT CABAZON, CALIFORNIA		
RECOMMENDED BY GENERAL MANAGER DATE			
REVISION	BY	DATE	1" DUAL SERVICE INSTALLATION
			STANDARD DRAWING W126A

DRAFT

ITEM	NO. REQ'D.	DESCRIPTION	APPROVED MATERIAL LIST NO.
1	1	1" SERVICE CONNECTION PER STANDARD DRAWING W124 OR STANDARD DRAWING W125.	SEE DWG. W124 OR DWG. W125
2	VARIES	1" TYPE "K" SOFT COPPER TUBING.	A-05
3	1	1" ANGLE METER STOP.	B-05
4	1	METER (SIZE AS SPECIFIED).	H-18
5	1	METER BOX.	E-01
6	1	1" STANDARD WEIGHT BRASS PIPE, 12" LONG.	A-06
7	1	1" FEMALE METER SWIVEL NUT x 1" x 1" MALE METER THREAD BRASS TEE.	N/A
8	1	1" BALL VALVE ASSEMBLY WITH 3 1/4" LONG HANDLE AND 2 LOCK EARS WITH IDENTIFICATION TAG.	B-08
9	1	ONE INLINE COUPLING MAY BE PERMITTED WHEN APPROVED BY DISTRICT.	H-12

NOTES:

1. COPPER SERVICE TUBING SHALL BE LAID STRAIGHT AND AT RIGHT ANGLES TO THE WATERMAIN.
2. METER BOX SHALL BE AT LEAST 5' FROM EDGE OF DRIVEWAY (CURB DROP) OR FROM DRIVEWAY RADIUS.
3. PIPE THREADS SHALL BE CLEAN AND SHARP AND SEALED WITH AN APPROVED JOINT COMPOUND.
4. METER BOX MAY BE PLACED BEHIND CURB OR BEHIND SIDEWALK. DISTRICT WILL SPECIFY LOCATION OF METER BOX.

APPROVED BY _____ <small>DISTRICT WATER ENGINEER RCE No. DATE</small>	CABAZON WATER DISTRICT CABAZON, CALIFORNIA
RECOMMENDED BY _____ <small>GENERAL MANAGER DATE</small>	1" DUAL SERVICE INSTALLATION
REVISION _____ BY _____ DATE _____	STANDARD DRAWING W126B

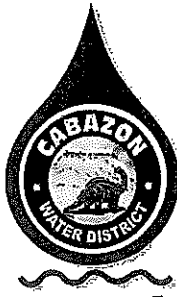

Cabazon Water District

14618 Broadway Street • P.O. Box 297
Cabazon, California 92230

Summary of Water Facilities Charges

This table summarizes the total charges required for water service to accommodate new water connections up to and including a 2 inch water meter service:

Meter Size (Inches)	Capacity Charge Per Meter (\$)	Service Connection Charge Per Meter (\$)	Total Charges (\$)
5/8 x 3/4	8,136	1,170	9,306
3/4	12,204	1,180	13,384
1	20,340	1,240	21,580
1-1/2	40,679	1,900	42,579
2	65,087	2,000	67,087

Business (951) 849-4442 • FAX (951) 849-2519

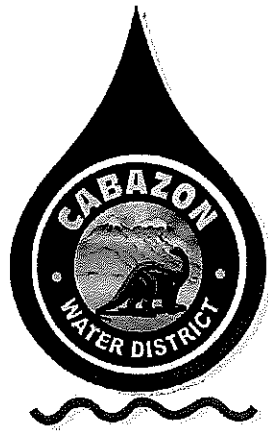

Current Water Rates Effective December 1, 2018

Meter Size	Monthly Service Charge
5/8"	\$ 61.77
3/4"	\$ 89.10
1"	\$ 143.78
1-1/2"	\$ 280.46
2"	\$ 444.48
3"	\$ 881.88
4"	\$ 1373.94
6"	\$ 2740.80
Contract Customer	\$ 2025.45

Monthly Commodity Charge

Tier 1: 0-700 ft ³	\$1.39 per 100 cubic feet
Tier 2: 800-1,400 ft ³	\$3.04 per 100 cubic feet
Tier 3: Over 1,400 ft ³	\$4.42 per 100 cubic feet
Contract Customer	\$4.64 per 100 cubic feet

RECORDING REQUESTED BY:

CABAZON WATER DISTRICT

AND WHEN RECORDED MAIL TO:

Best Best & Krieger LLP
Attn: Steven M. Anderson, Esq.
3390 University Ave.
5th Floor
Riverside, CA 92501

(Space above line for County Recorders use only)

No recording fees required pursuant to Rev. & Tax. Code § 11922; Gov. Code § 27383

WAIVER, RELEASE AND INDEMNITY AGREEMENT

THIS WAIVER, RELEASE AND INDEMNITY AGREEMENT (hereinafter, "Agreement") is made and entered into this _____ day of _____, 2019 ("Effective Date") by and between the Cabazon Water District ("District"), _____ ("Developer") and _____ ("Customer"), (collectively, the "Parties" and individually, the "Party").

A. Customer and Developer each desires to obtain water service from the District, including meter installation, related to that certain real property known as APN _____, and located at _____, Cabazon, California ("Property"), as described in Exhibit "1", attached.

B. Customer and Developer each acknowledges and understands that fire suppression services provided to the Property by a fire protection agency may utilize fire hydrants in proximity to the Property.

C. Customer and Developer each understands and acknowledges all of the following: (i) fire hydrants utilized to suppress fires affecting the Property may not provide fire flows equal to those set forth in Article 12 of the District's Rules and Regulations Governing Water Service; (ii) upgrading or otherwise achieving fire flow rates set forth in Article 12 would be costly and time consuming for the District; and (iii) Customer and Developer do not at the present wish to incur costs associated with achieving fire flow rates as presented by the District's Rules and Regulations Governing Water Service.

D. District hereby agrees to install a meter for water service to the Property subject to the terms and conditions set forth herein.

E. In the event future water demands relating to the Property require installing a larger water meter than the meter contemplated by this Agreement and related will-serve letter, Customer and Developer hereby agree to be responsible for any additional costs and District fees associated with installing the larger meter, as determined at the time the larger meter is installed.

F. In consideration of this Agreement and to the fullest extent permitted by law, each of Customer and Developer and their respective successors, assigns, principals, agents, employees,

consultants, representatives, bonding companies and insurers hereby release, forever discharge and waive any and all claims as against District, District's officers, successors, assigns, principals, agents, employees, consultants, representatives, attorneys, bonding companies and insurers from any and all liability, demands, causes of actions, or responsibility of any kind for claims, known or unknown, arising out of or in any way related to the provision of water service by the District, including but not limited to the provision of fire flow, to the Property ("Released Claims").

G. With respect to the Released Claims, Customer and Developer specifically each waives the provisions of Section 1542 of the California Civil Code, and any other similar statute or provision, which provides as follows:

A GENERAL RELEASE DOES NOT EXTEND TO CLAIMS WHICH THE CREDITOR DOES NOT KNOW OR SUSPECT TO EXIST IN HIS OR HER FAVOR AT THE TIME OF EXECUTING THE RELEASE, WHICH IF KNOWN BY HIM OR HER MUST HAVE MATERIALLY AFFECTED HIS OR HER SETTLEMENT WITH THE DEBTOR.

Customer and Developer each expressly waives and releases any right or benefit which Customer and Developer each has or may have under Section 1542 of the Civil Code of the State of California, to the full extent that such rights and benefits may be waived.

H. In consideration of this Agreement and to the fullest extent permitted by law, Customer and Developer each hereby agrees to indemnify, defend and hold District, its officers, employees, consultants, contractors and agents harmless from any damage, claim, liability, or cost (including attorney's fees and costs of defense) to the extent caused by, arising from or in any way related to the provision of water service by the District, including but not limited to the provision of fire flow, to the Property.

I. Each of the Parties hereby agrees that this Agreement is intended to be interpreted as broadly and inclusively as is permitted by the laws of the State of California, and that if any provision or portion thereof is held invalid, illegal, or otherwise unenforceable by a court of competent jurisdiction, it is agreed that the balance of the Agreement shall continue in full legal force and effect.

J. Customer and Developer each agrees that this Agreement shall be binding on his/her heirs, successors and assigns, including without limitation, future owners of the Property.

K. Customer and Developer, by signing below, each acknowledges that it has read and hereby voluntarily signs this Agreement, and that no oral representations, statements or inducement, apart from the foregoing written agreement, has been made, and that the undersigned possesses the legal power, right, and authority to bind each of Customer and Developer, respectively. Customer and Developer each further acknowledges that each of Customer and Developer understands that by signing this Agreement may be waiving valuable legal rights and that Customer and Developer, respectively, may at any time seek the advice of an attorney in any matter connected with this Agreement prior to signing.

IN WITNESS WHEREOF, the undersigned each hereby executes this Waiver, Release and Indemnity Agreement and make it effective as of the date first written above.

"District":	"Customer":	"Developer":
Cabazon Water District	[REDACTED]	[REDACTED]
By: _____	By: _____	By: _____
Name: _____	Title: _____	Name: _____
Title: _____	Dated: _____	Title: _____
Dated: _____		Dated: _____

DRAFT

EXHIBIT 1

Legal Description of APN 526-201-017

LOT 164 OF CABAZON VISTA, IN THE COUNTY OF RIVERSIDE, STATE OF CALIFORNIA, AS SHOWN BY MAP ON FILE IN BOOK 44, PAGES 21 AND 22 OF MAPS, RECORDS OF RIVERSIDE COUNTY, CALIFORNIA.

DRAFT

NOTARY ACKNOWLEDGMENT
(California All-Purpose Acknowledgment)

STATE OF CALIFORNIA)
) ss.
COUNTY OF _____)

On _____, 201__ before me, _____, notary public,
personally appeared _____, who proved to me on the basis of satisfactory
evidence to be the person(s) whose name(s) is/are subscribed to the within instrument and
acknowledged to me that he/she/they executed the same in his/her/their authorized capacity(ies),
and that by his/her/their signature(s) on the instrument the person(s) or the entity upon behalf of
which the person(s) acted, executed the instrument.

I certify under PENALTY OF PERJURY under the laws of the State of California that
the foregoing paragraph is true and correct.

WITNESS my hand and official seal.

Signature of Notary Public

NOTARY ACKNOWLEDGMENT
(California All-Purpose Acknowledgment)

STATE OF CALIFORNIA)
) ss.
COUNTY OF _____)

On _____, 201__ before me, _____ notary public personally appeared _____, who proved to me on the basis of satisfactory evidence to be the person(s) whose name(s) is/are subscribed to the within instrument and acknowledged to me that he/she/they executed the same in his/her/their authorized capacity(ies), and that by his/her/their signature(s) on the instrument the person(s) or the entity upon behalf of which the person(s) acted, executed the instrument.

I certify under PENALTY OF PERJURY under the laws of the State of California that the foregoing paragraph is true and correct.

WITNESS my hand and official seal.

Signature of Notary Public



MEMORANDUM

DATE: January 9, 2019
TO: Board of Directors
FROM: C. Louie
SUBJ: Community Water Service Alliance (CWSA)
cc: files

Attached are the string of email communications and various documents for your review.

Date	Classification	Description
11/29/2018	Email	CWSA Meeting 11/30/2018 -- Agenda & Location
11/30/2018	Document	Proposed CWSA agenda
12/03/2018	Document	Report: Organization of a Community Water Systems Alliance and proposed tier sponsor rates
12/10/2018	Email	CWSA Agenda & Meeting Documents
12/10/2018	Document	Draft of CWSA MOU
12/12/2018	Document	Twentynine Palms Water District notes on their Board's decision to join and fund CWSA
12/12/2018	Email	CWSA Meeting Summary from 12/11
01/02/2019	Email	CWSA MOU v.3 (12/17/2018)
01/02/2019	Document	MOU v.3 (12/17/2018)
01/03/2019	Email	CWSA Update & Issues to Review
01/08/2019	Email	CWSA Meeting Agenda
01/08/2019	Document	2019 CWSA Budget Draft
01/08/2019	Document	CWSA membership recruitment flyer

Calvin Louie

From: adan <adan@calmutuals.org>
Sent: Thursday, November 29, 2018 2:02 PM
To: Jones, Paul; Coats, Danielle; Zelaya, Sheila; Ray Kollisz; Lisa Yamashita Lopez; David A. Armstrong; Tim Worley; Katie Porter; Dan Ferons; donb@smwd.com; Leach, Jim; Kelly Gardner; Meggan Valencia; Jeff Armstrong; Denise Peralta; Jim Clampa; Lisa Ohlund; Stacy Taylor; Calvin Louie
Subject: Reminder: CWSA Meeting 11/30 11-1pm Agenda and Location
Attachments: CWSAagenda11_30_Reminder.pdf

Thank you for planning to participate in the potential formation of an alliance for community water systems serving small, older and poorer communities in California. Attached is an agenda that is reserving the majority of time for discussion. The meeting will be held at Eastern Municipal Water District Headquarters, and Eastern is graciously hosting lunch. I look forward to seeing you tomorrow. □

Address:
EASTERN MUNICIPAL WATER DISTRICT
2270 Trumble Road
Perris, CA 92570

Adan Ortega
Executive Director
CalMutuals
714 449-8403
adan@calmutuals.org

via Newton Mail

**Proposed Community Water System Alliance
Agenda
11 am – 1 pm
November 30, 2018**

**Location:
EASTERN MUNICIPAL WATER DISTRICT
2270 Trumble Road
Perris, CA 92570**

- 1. Introductions 5 min**
Welcome by Host: Paul Jones, EMWD
Attendees

- 2. Brief Background on Formation of CWSA 10 min**
Lisa Yamashita-Lopez & Adan Ortega, CalMutuals
Ray Kolisz, TPWD

- 3. Discussion About Key Issues of Common Interests 15 min.**
Dan Ferons, SMWD / FVMWC
- Water Tax
- SWRCB Economic Feasibility Guidelines for New MCL Standards
- Others?

- 4. Funding Options Discussion 15 min**
Adan Ortega, CalMutuals

- 5. Next Steps Up to 1:15**
Open Discussion



**Report: Organization of a Community Water Systems Alliance
December 3, 2019**

A meeting was held on Friday, November 30, 2018, to discuss possible support for an alliance of community water systems representing income limited and disadvantaged communities, at Eastern Municipal Water District. The meeting was attended by:

Paul Jones, General Manager, Eastern Municipal Water District
Danielle Coats, Senior Legislative Program Manager, Eastern Municipal Water District
Lisa Yamashita Lopez, President, CalMutuals & GM Rubio Cañon Land and Water Assn.
David Armstrong, Vice President, CalMutuals & GM South Mesa Water Co.
Jim Clampa, General Counsel, CalMutuals & Public Water Agency Group (PWAG)
Owen Sharp, General Manager, San Andreas Mutual Water Company
Sandy Caruba, Board Member, San Andreas Mutual Water Company
Carol Giannini, Board Member, Twentynine Palms Water District
Bob Coghil, Board Member, Twentynine Palms Water District
Ray Kollisz, General Manager, Twentynine Palms Water District
Denise Peralta Galley, Advocate, Twentynine Palms Water District
Dan Ferons, General Manager, Santa Margarita Water District
Don Barns, Assistant General Manager, Santa Margarita Water District
Jim Leach, Director of Government Affairs, Santa Margarita Water District
Kelly Gardner, Assistant Executive Director, San Gabriel Valley Water Association
Paul Gonsalves, Advocate, San Gabriel Valley Water Association
Stacy Taylor, External Affairs Manager, Mesa Water District
Jeff Armstrong, General Manager, Rancho California Water District
Meggan Valencia, Public Affairs Manager, Rancho California Water District
Calvin Louie, General Manager, Cabazon Water District
Curt Saur, Joshua Basin Water District
Jeff Deming, Principal, Monterey Bay Academy
Jackie McCloud, Utilities Manager, City of Watsonville
Lisa Ohlund, General Manager, East Orange Water District
Tim Worley, Executive Director, AWWA Cal-Nevada Section
Adan Ortega, Executive Director, CalMutuals

Meeting Purpose: To potentially augment resources through CalMutuals to include income-limited and disadvantaged communities, who are served by well run and operated water supply agencies, in organized efforts to prevent that their resources will be diverted by the state through the assessment of local taxes or economically infeasible regulations (i.e. Chromium 6).

Community Water Systems Alliance (CWSA) Principles

The group discussed seven principles around which CWSA would organize and advocate. CWSA will be comprised of a group of special districts, county water districts, community service districts, and cities that are well run and operated while serving disadvantaged communities and other populations that entail revenue limitations, such as seniors.

General draft organizing principles were revised to include the following:

1. CWSA is comprised of viable and well running water supply systems focused on empowering those among them who directly represent and serve the residents of disadvantaged communities and other populations with income limitations such as seniors
2. CWSA supports a statewide comprehensive needs-assessment of the operational integrity and resiliency of chronically distressed water systems
3. CWSA supports funding to build water system resiliency that does not shift existing resources of disadvantaged communities from some regions to other regions of the state
4. CWSA supports regulations that are deemed economically feasible through a combination of factors including affordability, transparent understanding of health benefits and their real-time cost and value to the residents of California
5. CWSA supports consolidation of chronically distressed water systems when it is part of an initiative supported by the residents of such communities, and where property rights and the right of representation is respected
6. CWSA members pledge to work with larger neighboring and/or regional water agencies toward efforts that bring resource efficiency, stewardship of local shared resources that are based upon common values, needs and respect not charity
7. CWSA is an alliance for education and advocacy of the common interests and empowerment of water systems serving disadvantaged communities and other income limited populations, not a permanent water association

Management – The group generally agreed that as fiscal sponsor, CalMutuals could bring efficiency to CWSA by availing it of its administrative, advocacy and logistical support eliminating the need for the duplication of resources, in parallel with CalMutuals’ regional capacity across the state. CalMutuals is proposing that an advisory board be comprised of the initial charter members according to the contribution levels below.

Budget - The group felt that the estimated budget of \$60,000 for one year to cover the legislative calendar was modest given the issues driving the organization of CWSA. The group asked CalMutuals to propose a sponsorship schedule scaled to the revenue capacity of prospective members (see contributions below).

Proposed Schedule for Regular Sponsors of the Initiative

CalMutuals has a “progressive” membership schedule that encourages participation by small and larger members. Pending consensus from the group, CalMutuals proposes the following scales of sponsorship for the Initiative:

Tier 1: Revenues <\$250K	\$500
Tier 2: Revenues \$250K +	\$750
Tier 3: Revenues \$500K+	\$1,250
Tier 4: Revenues \$1M+	\$2,500
Tier 5: Revenues \$4M+	\$5,000

Calvin Louie

From: adan <adan@calmutuals.org>
Sent: Monday, December 10, 2018 2:25 PM
To: Jackie McCloud; coatsd@emwd.org; David A. Armstrong; donb@smwd.com; Joe A. Gonsalves & Son; Jim Byerrum; Jim Ciampa; Leach, Jim; Kelly Jensen; Katie Porter; Ray Kolisz; Stacy Taylor; Meggan Valencia; Calvin Louie; Reeb, Bob; Danielle Blacet; Oz; Curt Sauer; Nunneley, Doug; mwest@bdvwa.org; mwest@bdvwa.org
Cc: Susan Allen
Subject: CWSA Agenda & Meeting Documents
Attachments: CWSA MOU (12-3-18) v.docx; CWSA Report1Summary.docx

Community Water System Alliance Participants and Potential Participants -

Below is call-in information, a draft agenda, a draft MOU, as well as the meeting report with proposed tiers for participation in the initiative - this information is also imbedded in the Calendar invitation. **As a reminder:** Our goal is to empower persons elected to represent disadvantaged communities to have a voice about issues such as the proposed water tax and the draft economic feasibility guidelines when they are released by the State Water Board.

Call-in Information: 1 858-284-1527. PIN: 764 612 631#

Draft Agenda:

1. Introductions
2. Membership Tiers (Please see CWSA Report1Summary.docx - Attached)
3. Draft MOU for Participation by Agencies (Please see CWSA MOU- Attached)
4. AB134 (Bloom)
5. Discussions with Committee Staff and Assm. E. Garcia
6. Next Steps

Adan Ortega
Executive Director
CalMutuals
714 449-8403
adan@calmutuals.org

via Newton Mail

**MEMORANDUM OF UNDERSTANDING
COMMUNITY WATER SYSTEMS ALLIANCE**

This Memorandum of Understanding (“MOU”) is entered into this ___ day of _____, 2018 (“Effective Date”) by and between the California Association of Mutual Water Companies, a California non-profit mutual benefit corporation (“Cal Mutuals”), and _____ (“Participant”) with respect to the following.

RECITALS

- A. There are numerous regulatory and legislative issues facing water suppliers in California, including, but not limited to, water quality standards, requirements to limit water losses, a potential water tax, funding mechanisms for low-income rate assistance and long-term water use efficiency requirements.
- B. There are numerous water suppliers serving disadvantaged and severely disadvantaged communities that while operating efficiently and well, do not, on an individual basis, have the financial resources to be able to effectively advocate with respect to the issues identified in Recital A.
- C. Cal Mutuals is a non-profit association formed to provide effective advocacy for, and to facilitate operational and educational resources to ensure effective and compliant operation and governance of, mutual water companies and other small water systems in California.
- D. Cal Mutuals has worked with various water systems to develop a collaborative program to assist water systems serving disadvantaged and severely disadvantaged communities with regulatory and legislative advocacy, as described in Section 1, below (the “Initiative”).
- E. The Community Water Systems Alliance (“CWSA”) is an alliance of water systems who are undertaking the Initiative, working with and through Cal Mutuals as described herein.
- F. Participant desires to participate in CWSA and desires to make a financial contribution to help offset the costs of the Initiative, in accordance with the provisions set forth below.

NOW, THEREFORE, Participant and Cal Mutuals agree as follows:

1. The Initiative. Cal Mutuals will provide the services necessary to administer and coordinate the functions relating to the Initiative, as guided by the principles attached hereto as Exhibit A and incorporated herein by this reference. Participant, in its sole discretion and at its sole cost, may provide services of its employees to assist with implementing the Initiative.

2. Participant's Financial Contribution. Participant shall contribute the sum of \$_____ to CWSA, through Cal Mutuals, in order to join and participate in CWSA. That amount may be paid in a lump sum or through a payment arrangement to be agreed upon by Participant and Cal Mutuals. Cal Mutuals shall separately account for all such contributions and shall utilize Participant's and other CWSA members' contributions only for costs related to the Initiative and its administration. Cal Mutuals shall issue a quarterly report of CWSA's income and expenses, including the use of Participant's contribution, on or before the thirtieth (30th) day following the end of each calendar quarter (i.e., March 31, June 30, September 30 and December 31). Participant acknowledges that the financial contributions of other CWSA members may vary and may be greater than or less than Participant's contributions, although Cal Mutuals will use its best efforts to ensure a fair structure concerning such overall contributions, including through application of the revenue-based contribution model set forth in Exhibit A hereto.

3. CWSA Participant Issues. Participant shall allow Cal Mutuals to use Participant's name in any correspondence that Cal Mutuals may send regarding the Initiative and in any materials used in soliciting additional members in CWSA; provided, however, that if such correspondence relates to a position on legislation, Participant shall be provided the opportunity to opt out of being specifically named in any such correspondence and Cal Mutuals will remove Participant's name if so instructed. Upon written request of Participant, Cal Mutuals shall promptly (i.e., within three business days) provide Participant by e-mail with a list of all participants in CWSA and their respective contributions.

4. Audit/Inspection. Upon at least forty-eight (48) hours' prior written notice, Participant may audit or inspect, at Participant's sole cost and expense, Cal Mutuals' accounting books and records relating to CWSA and the Initiative.

5. Term; Termination. This MOU shall have an indefinite term, although it is contemplated to last approximately two years. Because CWSA is intended to be a temporary program, it may be terminated at any time by the vote of at least sixty percent (60%) of its members. Participant may withdraw from CWSA at any time, upon at least seven (7) days' written notice. Such withdrawal shall not entitle Participant to a refund of any portion of its contribution under Section 2, above, unless any audit or inspection under Section 4, above, reveals the misappropriation of funds by Cal Mutuals, in which case CWSA shall be entitled to the return of its entire contribution or such other amount thereof as the parties may agree.

6. Indemnification. Cal Mutuals shall indemnify and defend Participant against any third party claims, losses, liabilities damages, lawsuits, claims, judgments or other costs resulting from Cal Mutuals' gross negligence or intentional misconduct in performing its duties hereunder.

7. Notices. Any notice or other communication to be provided under this MOU shall be in writing, and shall be deemed effectively given upon personal delivery; or upon deposit in any United States mail box, by registered, certified, Priority, or Express mail, postage prepaid; or upon delivery by nationally recognized overnight courier; or upon confirmed transmission by facsimile, addressed to the other party at the address shown below.

8. Governing Law. This MOU shall be governed by and construed in accordance with the laws of the State of California.

9. Amendment. This MOU may be modified only by a written agreement signed by both parties.

10. Severability. If any court determines that any provision of this MOU is invalid or unenforceable, any invalidity or unenforceability will affect only that provision and will not make any other provision of this MOU invalid or unenforceable and such provision shall be modified, amended or limited only to the extent necessary to render it valid and enforceable

11. Counterparts; Execution Transmitted by E-Mail or Fax. This MOU may be executed in counterparts, effective as of the Effective Date first set forth above. The parties agree that this MOU will be considered signed when the signature of a party is delivered by e-mail or by facsimile transmission. Such e-mailed or facsimile signature shall be treated in all respects as having the same effect of an original signature.

IN WITNESS WHEREOF, the Participant and Cal Mutuals have executed this MOU as of the date first above written.

D R A F T

California Association of Mutual Water Companies _____
Participant

By _____ By _____
Lisa Yamashita-Lopez, President Its _____

Address: 1370 N. Brea Blvd., Suite 238
Fullerton, CA 92835

Fax Number: _____

Address: _____

Fax Number: _____

TWENTYNINE PALMS WATER DISTRICT
72401 HATCH ROAD, TWENTYNINE PALMS, CA 92277-2935
760.367.7546 PHONE 760.367.6612 FAX

TO:	BOARD OF DIRECTORS
DATE:	DECEMBER 19, 2018
FROM:	RAY KOLISZ, GENERAL MANAGER
SUBJECT:	DISCUSSION OF COMMUNITY WATER SYSTEM ALLIANCE FORMATION AND APPROVAL TO CONTRIBUTE FUNDING

BACKGROUND AND DISCUSSION

As previously reported as part of the SMART initiative, we have been working to form an alliance of community water systems to give voice to elected officials who represent disadvantaged communities as is the case with Twentynine Palms Water District (TPWD). This is particularly important given that proposals to tax water at the meter have already surfaced for re-consideration by the legislature during 2019. We are also expecting the State Water Board to release draft economic feasibility guidelines that will impact the standard for Chromium 6 and other constituents.

On November 30, 2018, TPWD helped to organize and lead a gathering of 22 general managers and board members representing 14 water agencies stretching from Watsonville to the high desert and the Inland Empire to "jump-start" the Community Water System Alliance (CWSA). The California Association of Mutual Water Companies ("CalMutuals") is willing to act as fiscal sponsor. This avoids having to start a new water association. CalMutuals will manage accounting and the advocacy coordination on behalf of the group.

Among several needs, CWSA will use the funds to develop briefing materials reflecting the needs of disadvantaged communities, such as TPWD, that are successfully fending for ourselves. The funds will also be used to help poorer water districts send their representatives to public hearings in Sacramento and around the state. The original draft budget estimated costs at \$60,000 for one year, which those assembled on November 30th thought was too modest given the level of interest and need to have participation at the hearings and meetings ahead especially in Sacramento.

The group has so far agreed that residents of well-functioning disadvantaged communities should not be taxed to benefit chronically failing water systems in other parts of the state. We have agreed to work to find alternative funding sources that will also be available to agencies such as TPWD. The group has also agreed to look at other forms of mutual aid between well-functioning water systems and those that may be at the brink of failing.

RECOMMENDATION

Agencies that sponsor the initiative at \$10,000 or more will be part of a policy council that will guide the CWSA. TPWD has been urging others to support the effort, and it is thus my recommendation that TPWD agree to engage at the \$10,000 level. Upon approval from the Board the CWSA will draft a Memorandum of Understanding (MOU) to be presented to the Board for consideration.

Calvin Louie

From: adan <adan@calmutuals.org>
Sent: Wednesday, December 12, 2018 2:39 PM
To: Jones, Paul; Coats, Danielle; Lisa Yamashita Lopez; David A. Armstrong; Jim Ciampa; Ray Kolisz; Dan Ferons; donb@smwd.com; Leach, Jim; Kelly Gardner; Stacy Taylor; Jeff Armstrong; Meggan Valencia; Calvin Louie; Jackie McCloud; Lisa Ohlund; Tim Worley; mwest@bdvwa.org; Nunneley, Doug
Cc: Danielle Blacet; Katie Porter; Joe A. Gonsalves & Son; Kelly Jensen; Jim Byerrum; Reeb, Bob; Susan Allen
Subject: CWSA Meeting Summary from 12/11
Attachments: CWSA MOU (12-3-18) v.docx

Team -

The group considered several items during the CWSA call yesterday as appeared on the agenda:

Membership Tiers

There were no objections to the following sponsorship tiers for the CWSA initiative
Schedule for Regular Sponsors of the Initiative:

Tier 1: Revenues <\$250K	\$500
Tier 2: Revenues \$250K +	\$750
Tier 3: Revenues \$500K+	\$1,250
Tier 4: Revenues \$1M+	\$2,500
Tier 5: Revenues \$4M+	\$5,000

Charter Members Defined

Several water agencies will seek approval from their boards in the coming weeks to jump-start the CWSA initiative at levels of \$10,000 or more. Those agencies that donate more than \$10,000 will serve as the "executive committee" to review expenses and administrative matters through CalMutuals

Draft MOU for Participation by Agencies

No objections were raised to requests that "opt-out" provisions be inserted into the Participation MOU also applying to communications being sent to third-parties where positions, requests or group-inquiries are being made in written form. The current draft included an opt-out on legislative positions.

Given pending actions by boards considering participation in CWSA will take place over the next two weeks, it is requested that any further requests for revisions to the MOU be set to Adan Ortega by 5 pm on Monday, December 17, 2018. (The draft MOU is attached for your convenience)

AB134 (Bloom)

AB134 is a spot bill with no specific provisions (yet). But it is a potential vehicle that will be tracked.

Discussions with Committee Staff and Assm. E. Garcia

As previously reported, a joint committee hearing will be held early in '19 comprised of the Assembly Water, Parks & Wildlife Committee, Assem. Environmental Quality Committee, and Budget Committee

#3. Participation by disadvantaged communities that were not part of last year's debate is strongly encouraged.

Assem. Garcia will also be visiting other areas with Disadvantaged Communities that are succeeding and struggling. These may include Southeast Los Angeles/San Gabriel Valley, Los Desert Areas and the Central Coast.

Next Steps

1. Comments on draft MOU are due Mon. Dec. 17th at 5pm (please send to Adan Ortega)
2. Identify representatives from agencies serving Disadvantaged Communities that may be available for hearings/testimony.
3. Schedule follow-up call on the week of Jan. 7th. Potential agenda items include a)status on hearings; b) status of regional visits by Assm. Garcia & legislative Taskforce c) roster of agencies that have joined CWSA; d) briefing on human right to water proposals by ACWA and others; e) consideration of initial talking points; d) other items as suggested during the interim.

Adan Ortega
Executive Director
CalMutuals
714 449-8403
adan@calmutuals.org

via Newton Mail

On Mon, Dec 3, 2018 at 12:48 PM, adan <adan@calmutuals.org> wrote:
Team -

Once again, I'd like to thank Eastern Municipal Water District for hosting a meeting last Friday (Nov. 30) about the possible formation of an alliance of water supply systems that directly represent Disadvantaged Communities and other populations with income limitations. Attached is a document summarizing the discussion we had at Eastern. I think we made great progress to launch this initiative. Please review the principles as I tried to reflect the comments made during the meeting. We are planning to have a conference call during the week of December 10th. If you did not attend the meeting on the 30th but would like to participate on the call during the week of December 10th, please reply to this email and let me know. In the meantime, please feel free to call me if you have any questions (714 600-4683).

Thank you!

Adan Ortega
Executive Director
CalMutuals
714 449-8403
adan@calmutuals.org

via Newton Mail

Calvin Louie

From: adan <adan@calmutuals.org>
Sent: Wednesday, January 2, 2019 3:45 PM
To: Lisa Ohlund; Ray Kollisz; Calvin Louie; Dan Ferons; Jones, Paul; Coats, Danielle; Curt Sauer; Nunneley, Doug
Cc: Susan Allen; Jim Ciampa
Subject: CWSA MOU
Attachments: CWSA MOU v.3 (12-17-18).docx

Here is the final version of the MOU for the Community Water Systems Alliance. It addresses three factors raised during our last conference call: 1) Expanded opt-out; 2) Indemnification; 3) Clarifies the sponsorship tiers and the advisory board status/role of those who contribute \$10k or more. We will schedule a call for late next week with the advisory group to review the initial budget, and initial proposed steps that we will take to the broader group. Please feel free to call me at 714 600-4683 if you have any questions.
Adan

Adan Ortega
Executive Director
CalMutuals
714 449-8403
adan@calmutuals.org

via Newton Mail

**MEMORANDUM OF UNDERSTANDING
COMMUNITY WATER SYSTEMS ALLIANCE**

This Memorandum of Understanding ("MOU") is entered into this ___ day of _____, 2018 ("Effective Date") by and between the California Association of Mutual Water Companies, a California non-profit mutual benefit corporation ("Cal Mutuals"), and _____ ("Participant") with respect to the following.

RECITALS

- A. There are numerous regulatory and legislative issues facing water suppliers in California, including, but not limited to, water quality standards, requirements to limit water losses, a potential water tax, funding mechanisms for low-income rate assistance and long-term water use efficiency requirements.
- B. There are numerous water suppliers serving disadvantaged and severely disadvantaged communities that, while operating efficiently and well, do not, on an individual basis, have the financial resources to be able to effectively advocate with respect to the issues identified in Recital A.
- C. Cal Mutuals is a non-profit association formed to provide effective advocacy for, and to facilitate operational and educational resources to ensure effective and compliant operation and governance of, mutual water companies and other small water systems in California.
- D. Cal Mutuals has worked with various water systems to develop a collaborative program to assist water systems serving disadvantaged and severely disadvantaged communities with regulatory and legislative advocacy, as described in Section 1, below (the "Initiative").
- E. The Community Water Systems Alliance ("CWSA") is an alliance of water systems who are undertaking the Initiative, working with and through Cal Mutuals as described herein.
- F. Participant desires to participate in CWSA and desires to make a financial contribution to help offset the costs of the Initiative, in accordance with the provisions set forth below.

NOW, THEREFORE, Participant and Cal Mutuals agree as follows:

1. The Initiative. Cal Mutuals will provide the services necessary to administer and coordinate the functions relating to the Initiative, as guided by the principles attached hereto as Exhibit A and incorporated herein by this reference. Participant, in its sole discretion and at its sole cost, may provide services of its employees to assist with implementing the Initiative. Participant shall cooperate with Cal Mutuals in coordinating and organizing any such services that are to be provided in conjunction with the Initiative.

2. Participant's Financial Contribution; Charter Membership. (a) Cal Mutuals has established the following dues structure for Participants to join and participate in CWSA:

<u>REVENUE TIERS</u>	<u>DUES</u>
<u>Tier 1: Annual Gross Revenues of less than \$250,000</u>	<u>\$500</u>
<u>Tier 2: Annual Gross Revenues between \$250,000 and \$499,999</u>	<u>\$750</u>
<u>Tier 3: Annual Gross Revenues between \$500,000 and \$999,999</u>	<u>\$1,250</u>
<u>Tier 4: Annual Gross Revenues between \$1,000,000 and \$3,999,999</u>	<u>\$2,500</u>
<u>Tier 5: Annual Gross Revenues of \$4,000,000 and higher</u>	<u>\$5,000</u>
<u>Charter Member (see subsection (c))</u>	<u>At least \$10,000</u>

(b) Participant's annual gross revenues place it in Tier , and Participant shall therefore pay dues of \$. [or: Participant has agreed to contribute \$ in consideration of its Charter Membership pursuant to subsection (c), below]. shall contribute the sum of \$ to CWSA, through Cal Mutuals, in order to join and participate in CWSA. That amount may be paid in a lump sum or through a payment arrangement to be agreed upon by Participant and Cal Mutuals. The amount shall be payable by check payable to Cal Mutuals or by wire transfer or other electronic funds transfer in the manner directed by Cal Mutuals. Cal Mutuals shall separately account for all such contributions and shall utilize Participant's and other CWSA members' contributions only for costs related to the Initiative and its administration. Cal Mutuals shall issue a quarterly report of CWSA's income and expenses, including the use of Participant's contribution, on or before the thirtieth (30th) day following the end of each calendar quarter (i.e., March 31, June 30, September 30 and December 31). Participant acknowledges that, with the exception of the dues structure set forth in subsection (a), above, the financial contributions of other CWSA members may vary and may be greater than or less than Participant's contributions, although Cal Mutuals will use its best efforts to ensure a fair structure concerning such overall contributions, including through application of the revenue-based contribution model set forth in Exhibit A hereto.

(c) Charter Members shall contribute at least \$10,000 in support of the Initiative. As consideration for such contributions, a representative from each Charter Member shall serve on the Advisory Board for CWSA, along with Cal Mutuals' Executive Director. The Advisory Board shall periodically review CWSA's finances and shall approve any expenditures exceeding \$1,000. The Advisory Board shall also consult with Cal Mutuals' Executive Director to ensure the goals of the Initiative are being properly pursued.

2.3. CWSA Participant Issues. Participant shall allow Cal Mutuals to use Participant's name in any correspondence that Cal Mutuals may send regarding the Initiative and in any materials used in soliciting additional members in CWSA; provided, however, that if such correspondence relates to any position CWSA will be taking, including, but not limited to legislation or regulatory matters, Participant shall be provided the opportunity to opt out of being specifically named in any such correspondence by notifying Cal Mutuals by telephone or e-mail within twenty-four (24) hours after being notified of the position CWSA proposes to take. -and If the Participant desires to opt out from being included on any such communication, Cal Mutuals

will remove Participant's name ~~from the communication if so instructed~~. Upon written request of Participant, Cal Mutuals shall promptly (i.e., within three business days) provide Participant by e-mail with a list of all participants in CWSA and their respective contributions.

3.4. Audit/Inspection. Upon at least forty-eight (48) hours' prior written notice, Participant may audit or inspect, at Participant's sole cost and expense, Cal Mutuals' accounting books and records relating to CWSA and the Initiative.

4.5. Term; Termination. This MOU shall have an indefinite term, although it is contemplated to last approximately two years. Because CWSA is intended to be a temporary program, it may be terminated at any time by the vote of at least sixty percent (60%) of its members. Participant may withdraw from CWSA at any time, upon at least seven (7) days' written notice. Such withdrawal shall not entitle Participant to a refund of any portion of its contribution under Section 2, above, unless any audit or inspection under Section 4, above, reveals the misappropriation of funds by Cal Mutuals, in which case CWSA shall be entitled to the return of its entire contribution or such other amount thereof as the parties may agree.

5.6. Indemnification. Cal Mutuals shall indemnify and defend Participant, and its members, directors, officers, employees and agents, against any third party claims, losses, liabilities damages, lawsuits, claims, judgments or other costs resulting from Cal Mutuals' gross negligence or intentional misconduct in performing its duties hereunder. In the event Participant provides employees to render services in conjunction with the Initiative, Participant shall indemnify and defend Cal Mutuals, and its members, directors, officers, employees and agents, against any third party claims, losses, liabilities damages, lawsuits, claims, judgments or other costs resulting from the gross negligence or intentional misconduct or any employee of Participant in rendering such services.

6.7. Notices. Any notice or other communication to be provided under this MOU shall be in writing, and shall be deemed effectively given upon personal delivery; or upon deposit in any United States mail box, by registered, certified, Priority, or Express mail, postage prepaid; or upon delivery by nationally recognized overnight courier; or upon confirmed transmission by facsimile, addressed to the other party at the address shown below.

7.8. Governing Law. This MOU shall be governed by and construed in accordance with the laws of the State of California.

8.9. Amendment. This MOU may be modified only by a written agreement signed by both parties.

9.10. Severability. If any court determines that any provision of this MOU is invalid or unenforceable, any invalidity or unenforceability will affect only that provision and will not make any other provision of this MOU invalid or unenforceable and such provision shall be modified, amended or limited only to the extent necessary to render it valid and enforceable

10.11. Counterparts; Execution Transmitted by E-Mail or Fax. This MOU may be executed in counterparts, effective as of the Effective Date first set forth above. The parties agree

that this MOU will be considered signed when the signature of a party is delivered by e-mail or by facsimile transmission. Such e-mailed or facsimile signature shall be treated in all respects as having the same effect of an original signature.

IN WITNESS WHEREOF, the Participant and Cal Mutuals have executed this MOU as of the date first above written.

California Association of Mutual Water Companies

Participant

By _____
Lisa Yamashita-Lopez, President

By _____
Its _____

Address: 1370 N. Brea Blvd., Suite 238
Fullerton, CA 92835

Address: _____

Fax Number: _____

Fax Number: _____

DRAFT

Calvin Louie

From: adan <adan@calmutuals.org>
Sent: Thursday, January 3, 2019 2:34 PM
To: Jones, Paul; Coats, Danielle; Lisa Yamashita Lopez; David A. Armstrong; Jim Ciampa; Ray Kolisz; Dan Ferons; donb@smwd.com; Leach, Jim; Kelly Gardner; Joe A. Gonsalves & Son; Stacy Taylor; Jeff Armstrong; Meggan Valencia; Calvin Louie; Jackie McCloud; Lisa Ohlund; Tim Worley; Nunneley, Doug; mwest@bdvwa.org; Curt Sauer; Reeb, Bob; Dennis Albiani
Cc: Danielle Blacet; Katie Porter; Kelly Jensen; Jim Byerrum; Susan Allen
Subject: CWSA UPDATE & ISSUES TO REVIEW

Team - 

Happy New Year! I am writing to report about the status of members and urgent issues that will either result and/or influence potential legislation we are concerned about with respect to meter taxes.

First, as of this date, the following agencies have pending or completed action with their respective boards to approve participation in the Community Water Systems Alliance. These include:

Santa Margarita Water District*
Twentynine Palms Water District*
Mesa Water District*
East Orange County Water District*
Cabazon Water District ^
North of the River Water District#
Big Horn Water District*
Joshua Basin Water District ^
Eastern Municipal Water District*

*denotes Advisory Board Level ^ denotes undetermined level #tiered membership level

Others are pending their internal management evaluation and I will keep you posted. If you run an association and represent agencies with disadvantaged communities, or have neighboring systems, please feel free to refer them and I will call them on your behalf. It is imperative that we have a solid roster of officials from around the state that are elected to represent persons in cities and water districts that are from disadvantaged communities.

ISSUES

While the legislature returns to session on January 7th., two critical reports have been released for public comment with tight deadlines the first week of February. We are currently reviewing them and will develop draft comment letters for your review. In the meantime here are the links for your study, review and feedback. These two reports will have an influence on continuing legislative discussions about a potential residential/business meter tax to pay for O&M under a current effort to help chronically failing systems, mostly in parts of the Central Valley.

State Water Resources Control Board AB401(Dodd) Low Income Water Rate Assistance Program - This draft report to the legislature outlines options for how the program could be funded and administered. Deadline for comments: Feb 1

https://www.waterboards.ca.gov/water_issues/programs/conservation_portal/assistance/

OEHHA Draft Framework and Took for Evaluating Progress on the Human Right to Water

Addresses water quality, access to water, and affordability in the metric for evaluating progress in providing water to all. Deadline for comments: Feb 4

<https://oehha.ca.gov/water/report/human-right-water-california>

We will keep you posted on any further developments.

Best,

Adan

Adan Ortega
Executive Director
CalMutuals
714 449-8403
adan@calmutuals.org

via Newton Mail

On Mon, Dec 3, 2018 at 12:48 PM, adan <adan@calmutuals.org> wrote:

Team -

Once again, I'd like to thank Eastern Municipal Water District for hosting a meeting last Friday (Nov. 30) about the possible formation of an alliance of water supply systems that directly represent Disadvantaged Communities and other populations with income limitations. Attached is a document summarizing the discussion we had at Eastern. I think we made great progress to launch this initiative. Please review the principles as I tried to reflect the comments made during the meeting. We are planning to have a conference call during the week of December 10th. If you did not attend the meeting on the 30th but would like to participate on the call during the week of December 10th, please reply to this email and let me know. In the meantime, please feel free to call me if you have any questions (714 600-4683).

Thank you!

Adan Ortega
Executive Director
CalMutuals
714 449-8403
adan@calmutuals.org

via Newton Mail

Calvin Louie

From: adan <adan@calmutuals.org>
Sent: Tuesday, January 8, 2019 3:45 PM
To: Calvin Louie; Curt Sauer; Ferons, Dan; donb@smwd.com; Leach, Jim; Nunneley, Doug; Jim Ciampa; Lisa Ohlund; Ray Kolisz; Jim Byerrum; Lisa Yamashita Lopez; Stacy Taylor; Jones, Paul; Coats, Danielle
Subject: CWSA 4 pm meeting documents
Attachments: 2019 CWSA Budget DRAFT 01.03.xlsx; CWSAFlyer.docx

Team -

The calendar notice contains the draft agenda and meeting items. However, realizing that not everyone's system is compatible with google, here they are via email. ☐

Description: Agenda

1. Review of Participants and Prospective Participants
 - Review of Flyer (Attached)
2. Budget Review (Attached)
3. Advocacy -
 - a. AB401/OEHHA Letters - Preference of Joint Letter or Template for individual use
 - b. Request for list of directors/elected officials who represent DAC divisions/districts
4. Scheduling general meeting and agenda

Adan Ortega
Executive Director
CalMutuals
714 449-8403
adan@calmutuals.org

Member Contributions	\$72,500-\$85,000	A
Total Income	\$72,500-\$85,000	
EXPENSE		
First Year Activities		
Advocacy & Representation (Lobbyist) Support	20,000	
Coordination & Analysis of Issues & Activities (OSG)	18,000	
Legal Fees (Lagerlof, Senecal, Gosney & Kruse)	6,000	
Travel (Staff & Smaller Members)	8,000	
CalMutuals Administrative Fee	6,000	
Communications & Graphic Design Support	2,000	
Total Expense	60,000	
Beginning Reserve	\$12,000-\$25,000	B
Net Total		
NOTES		
A Reflects contrltions of from members as		
Blg Horn Water District ^	\$2,500-\$10,000	(Monthly)
Cabazon Water District #	\$5,000-\$10,000	(Monthly)
Eastern Municipal Water District *	\$10,000	
East Orange County Water District #	\$10,000	
Mesa Water District #	\$10,000	
North of the River Municipal Water District #	\$5,000	
Santa Margarita Water District *	\$20,000	
Twentynine Palms Water District *	\$10,000	
	\$72,500-\$85,000	

^ Board Action beginning in January
Board Action completed in January
* Final Action taken

- B** Contributions beyond \$60,000 to be invested in Reserve
- Pending:
 - City of Coachella
 - City of Watsonville
 - Coachella Valley Water District
 - Henry Miller Irrigation District
 - Joshua Basin Water District
 - Mojave Water Agency
 - Palmdale Water District
 - Rancho California Water District
 - Santa Ynez Conservation District



Community Water Systems Alliance

The Community Water Systems Alliance is an initiative in California to provide a voice in Sacramento for water systems serving disadvantaged communities that are reliably and affordably providing water to low income and income limited residents such as seniors.

What We Care About:

We want to preserve the ability of local water suppliers that provide water to disadvantaged and income limited communities to provide safe and affordable water through efficiency, good management practices and fairness. We care about legislation and regulations that affect disadvantaged and income limited communities where our community voices need to be heard.

What Threatens Safe Drinking Water for Our Communities:

Pending legislation may propose to levy water meter taxes that could transfer our local revenues to other parts of the state. The State Water Resources Control Board is soon considering economic feasibility guidelines for evaluating the viability of drinking water standards like Chromium 6.. These two factors may damage the viability of well operated water systems serving disadvantaged communities around the state.

What do we want?

Our communities want a seat at the table as legislation and regulations are considered affecting disadvantaged communities so we can advocate for:

- Equitable grant programs that don't discriminate against suppliers serving disadvantaged communities with more than 10,000 customers
- A revenue source to help disadvantaged communities that is not based upon regressive taxes that shift funds from some disadvantaged and income limited communities to others
- Strategies for dealing with chronically failing water systems that don't burden or typecast water systems serving disadvantaged and income limited communities that are functioning well

Where are we from?

Participating agencies in CWSA stretch from California's Central Valley, the greater Los Angeles Basin, Coachella Valley and the high desert's Morongo Basin.